

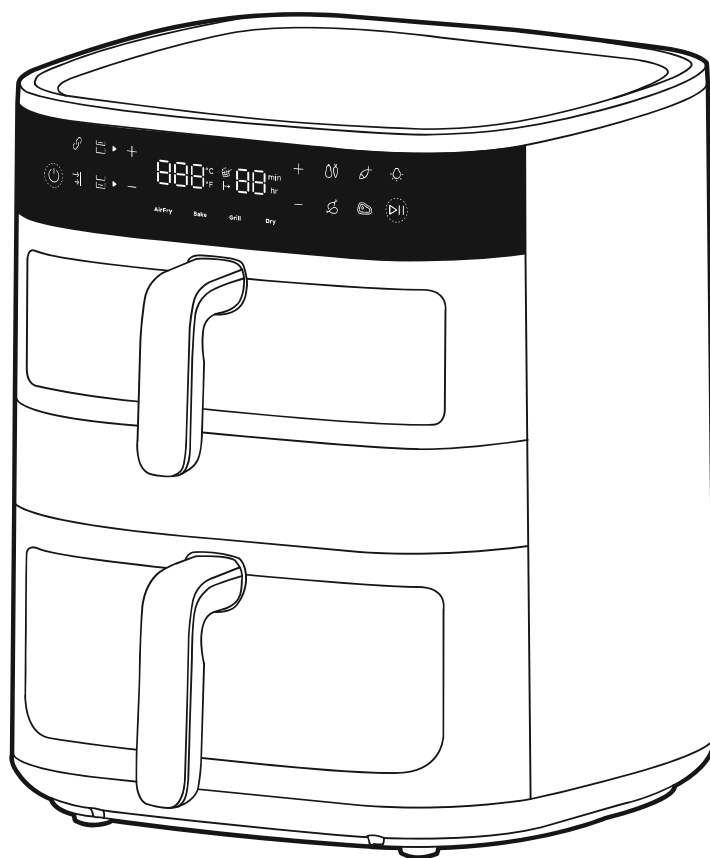

Electrolux

Priručnik s uputama



800 dvostruka friteza na vrući zrak

Opći pregled

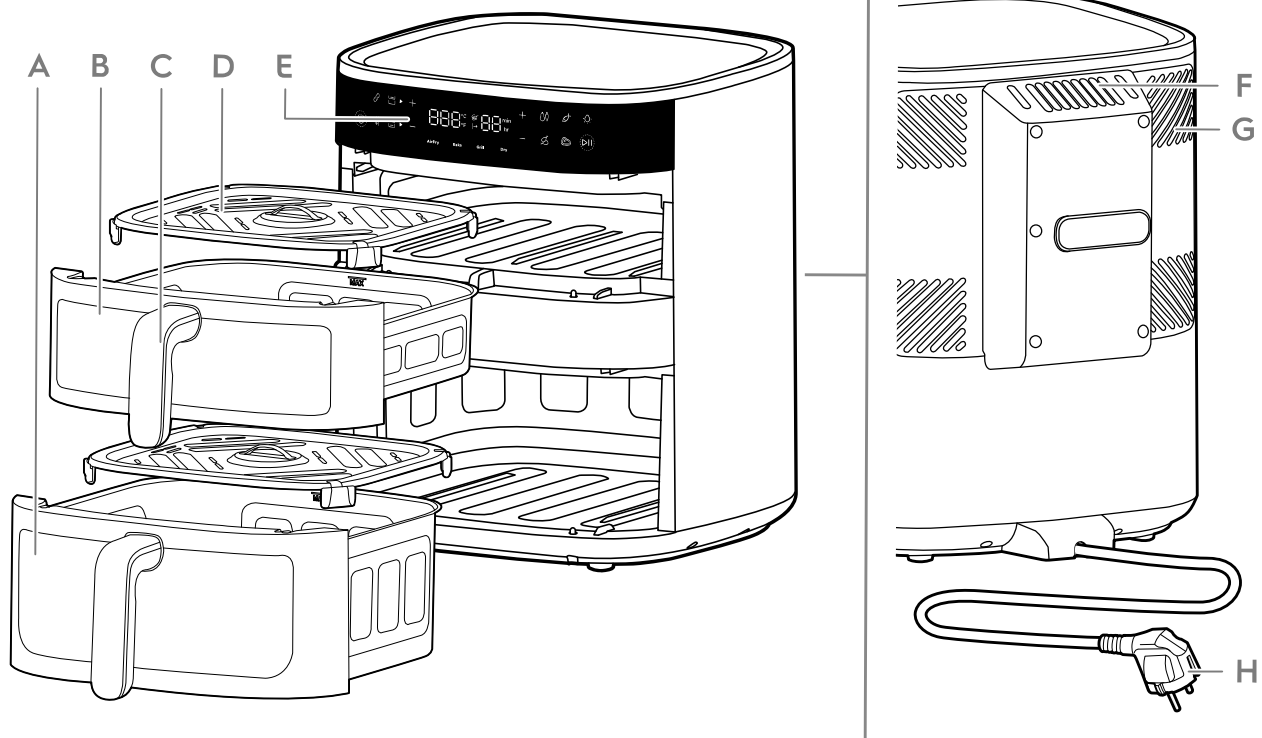

- | | | | |
|----------------------|----------------|-------------------|-------------------|
| A Donja košara (7L) | C Drška košare | E Kontrolna ploča | G Sustav hlađenja |
| B Gornja košara (4L) | D Rešetka | F Izlaz zraka | H Glavni kabel |

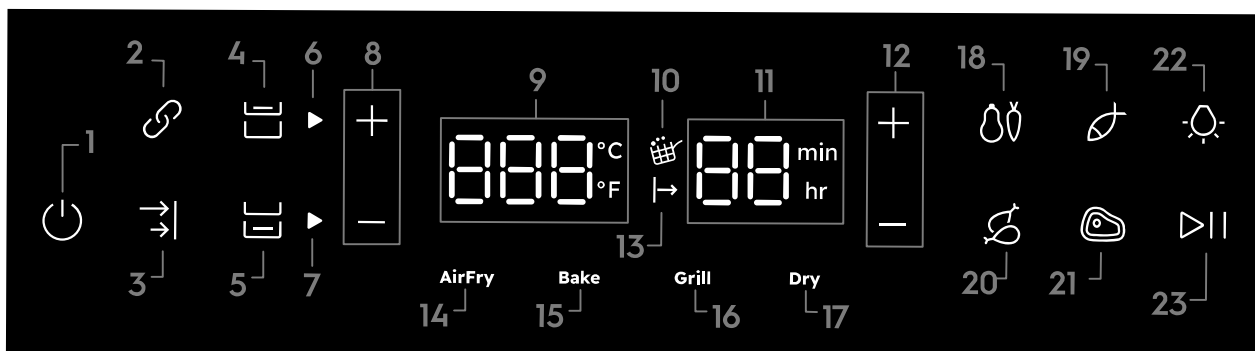

- | | | | |
|--------------------------------------|---|--|-------------------------|
| 1. Uključivanje/isključivanje | 6. Indikator gornje košare | 11. Indikator vremena (AirFry: 1 do 99 min, dehidracija: 1 do 5 h) | 17. Funkcija sušenja |
| 2. Funkcija povezivanja | 7. Indikator donje košare | 12. Upravljanje vremenom | 18. Povrće |
| 3. Funkcija sinkronizacije završetka | 8. Reguliranje temperature | 13. Čekanje pripreme hrane | 19. Riba |
| 4. Upravljanje gornjom košarom | 9. Indikator temperature (40 do 200 °C) | 14. Funkcija AirFry | 20. Piletina |
| 5. Upravljanje donjom košarom | 10. Podsjetnik za protresanje | 15. Funkcija pečenja | 21. Odrezak |
| | | 16. Funkcija roštilja | 22. Reguliranje svjetla |
| | | | 23. Reprodukcija/pauza |

Prije prve upotrebe

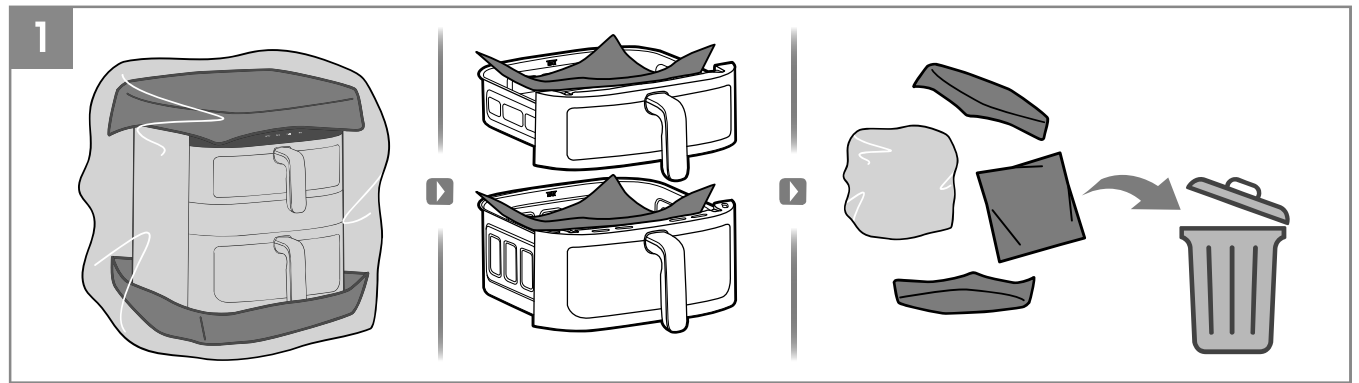

1. Uklonite svu ambalažu i zaštitni materijal.

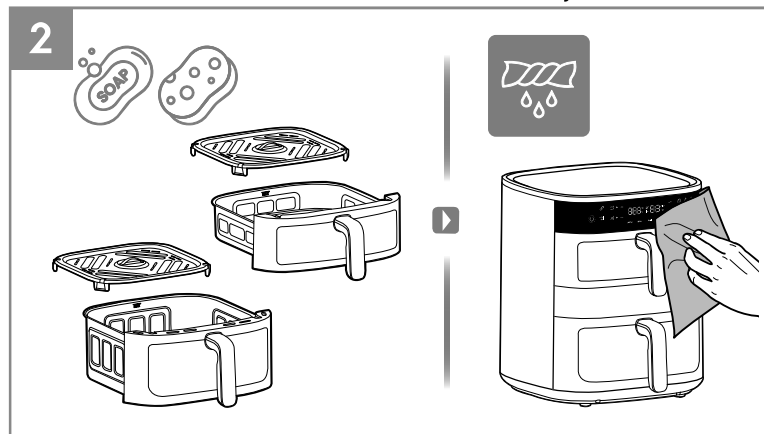

2. Očistite posudu i rešetku toplom vodom i sapunom za posuđe. Obrišite uređaj iznutra i izvana mekom krpom.

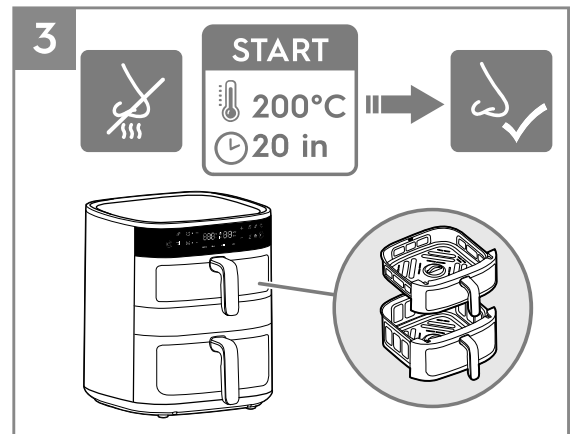

3. Normalno je da novi uređaj ispušta neugodne mirise pri prvih nekoliko upotreba. Kako biste to izbjegli, prije prve upotrebe pustite praznu fritezu na vrući zrak da radi 20 minuta na 200 °C.



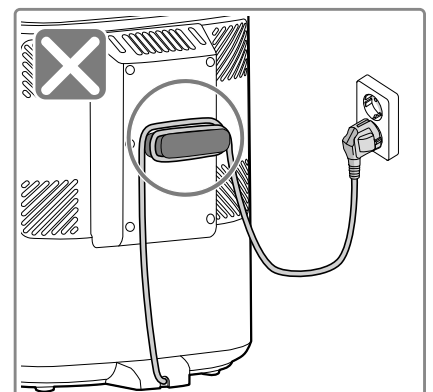
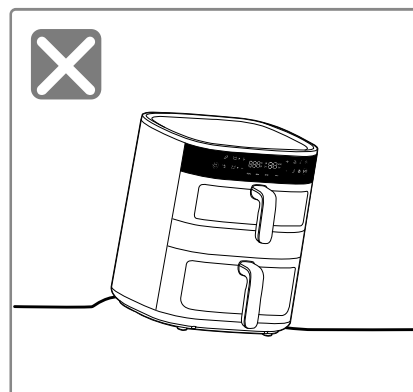
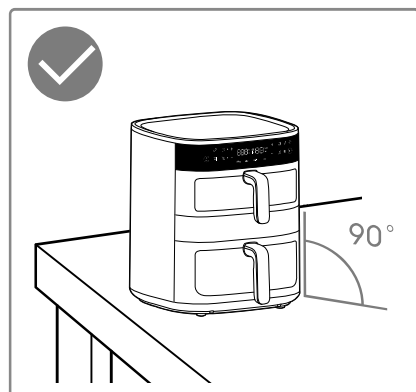
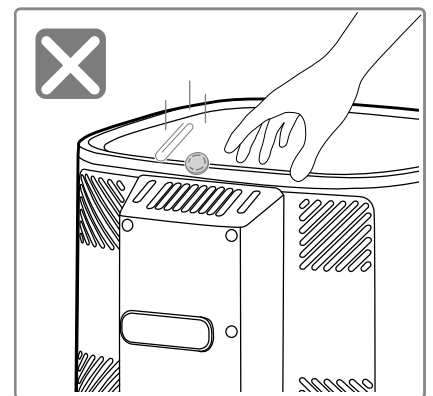
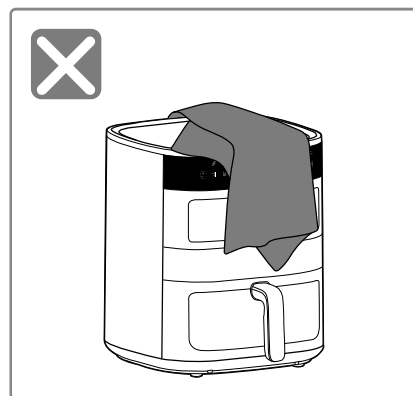
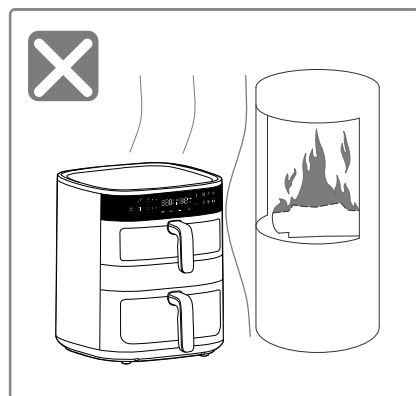



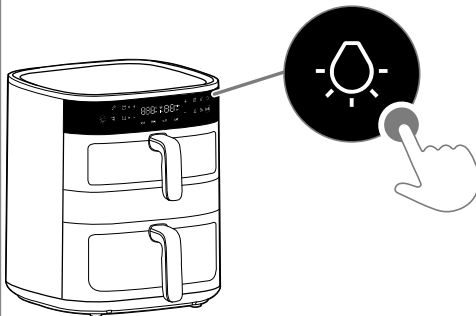
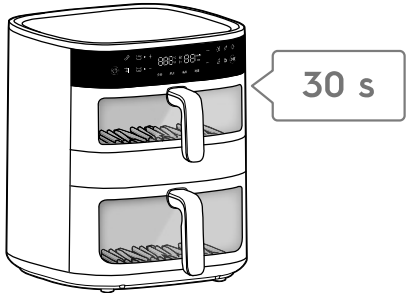
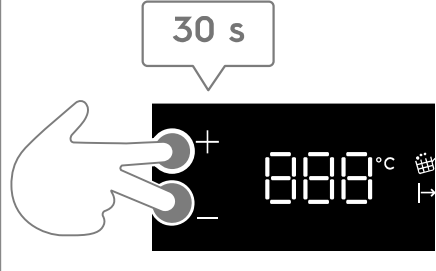
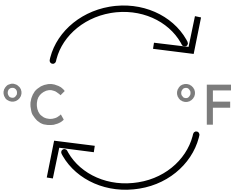



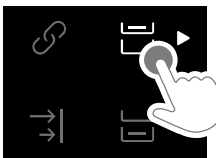
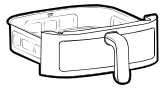

! Mjere sigurnosti



Reguliranje svjetla i pretvorba ljestvice temperature





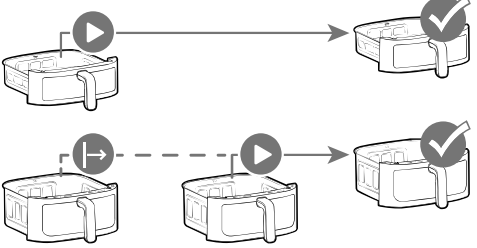







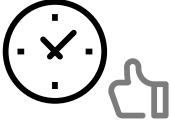

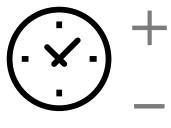
 <p>Reguliranje svjetla</p>		
<p>°C/°F</p> <p>Pretvorba skale za temperaturu</p>		

Odabir košare

	 <p>4L</p>	 <p>7L</p>	
 <p>Gornja košara</p>			
 <p>Donja košara</p>			
 <p>Funkcija povezivanja</p>			
 <p>Funkcija sinkronizacije završetka</p>			

- EN
- BG
- CZ
- DE
- DK
- EE
- FI
- FR
- GR
- HR**
- HU
- IT
- LT
- LV
- NO
- NL
- PL
- PT
- RO
- RU
- SE
- SI
- SK
- SR
- TR
- UA
- ES
- GE
- AL

Unaprijed postavljene funkcije

					
AirFry	180°C	15in	60~200°C	1~99in	
	170°C	10in	60~200°C	1~99in	
	140°C	15in	60~200°C	1~99in	
	180°C	30in	60~200°C	1~99in	
	200°C	10in	60~200°C	1~99in	
Bake	170°C	15in	60~200°C	1~99in	
Grill	200°C	5in	60~200°C	1~99in	
Dry	80°C	5h	40~80°C	1~5h	

Prije pripreme hrane

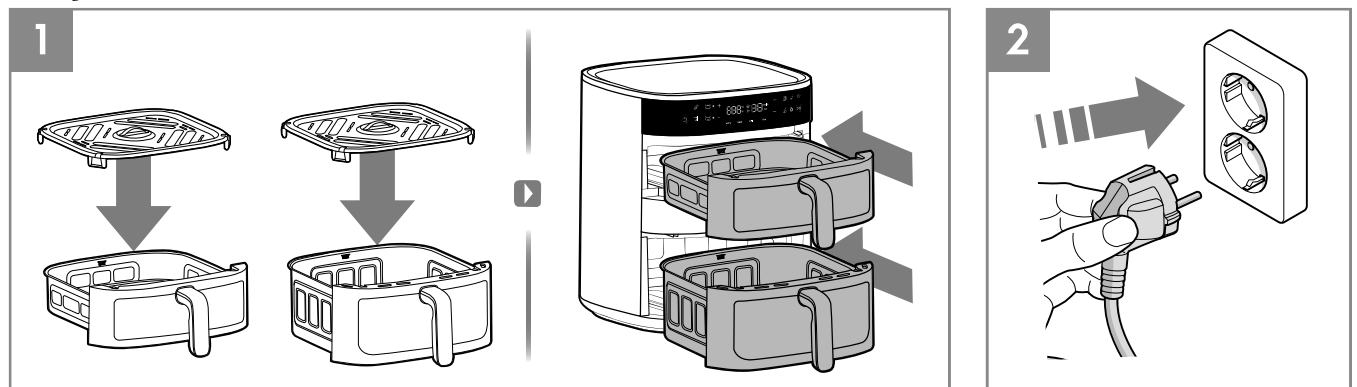

1. Prije svake pripreme hrane stavite rešetku u košaru (silikonsku podlogu rešetke otpornu na toplinu nije potrebno uklanjati) i potpuno gurnite košaru u uređaj.
2. Gurnite utikač u električnu utičnicu.

Kako koristiti – jedna košara

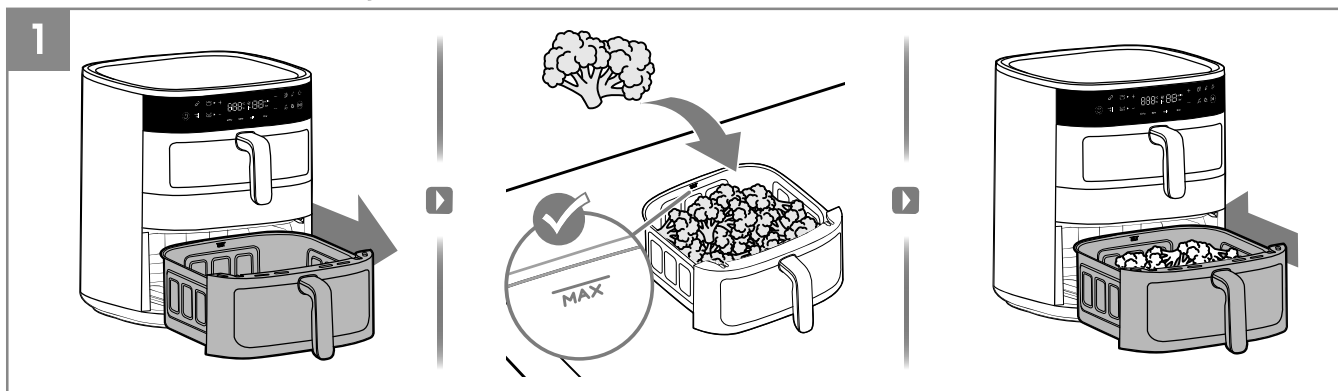

1. Izvucite jednu košaru i stavite je na stabilnu površinu, stavite hranu u košaru, pazeći na oznaku kapaciteta "MAX". Zatim košaru s hranom potpuno vratite u uređaj.

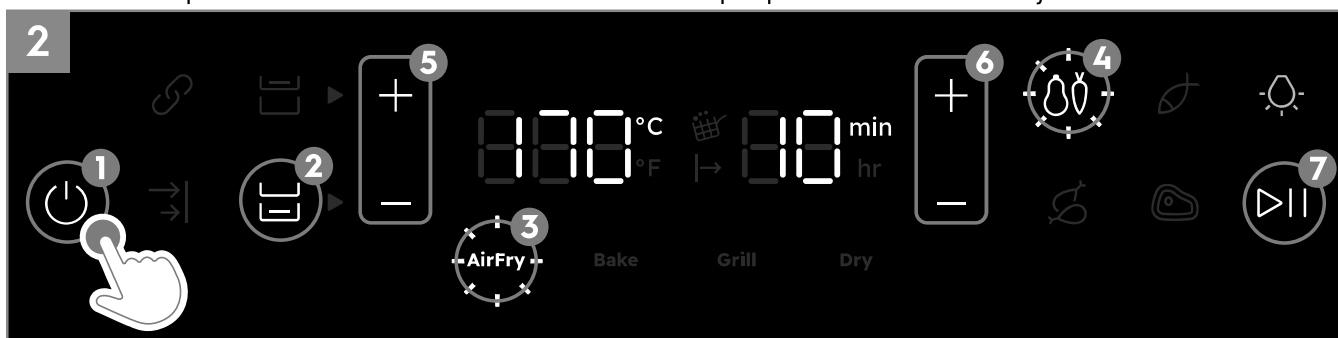

2. Pritisnite gumb za uključivanje/isključivanje. Prvo odaberite košaru s hranom. Zatim odaberite željeni način pripreme hrane, primjerice, funkciju Air Fry. Prilagodite vrijeme i temperaturu na željenu razinu ili odaberite jedan od unaprijed postavljenih recepata, primjerice, Povrće. Naposljetku pritisnite gumb za reprodukciju/pauzu.

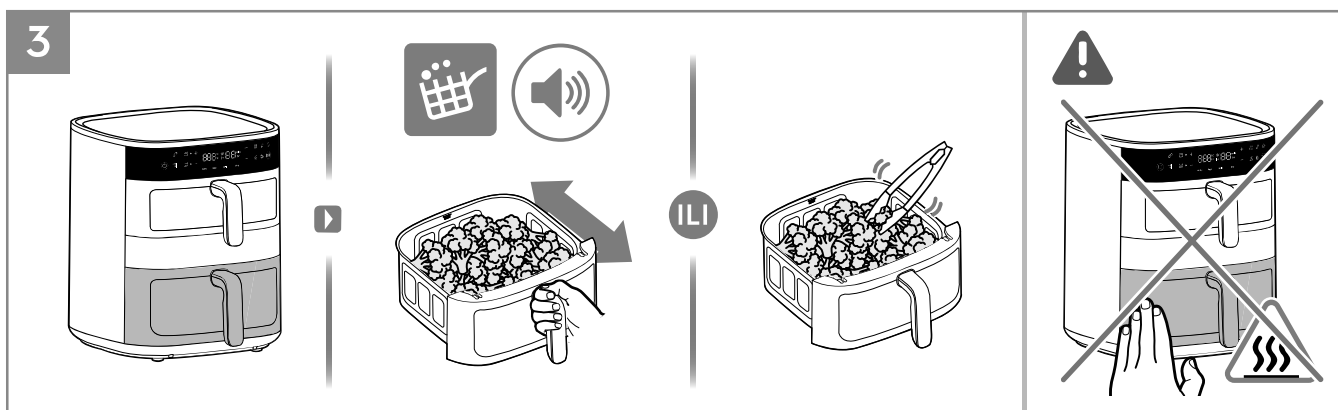

3. Ako se tijekom pripreme hrane uključi ikona "podsjetnika za protresanje" i oglasi se zvučni signal, alatima otpornima na toplinu jednom okrenite hranu ili lagano i pažljivo protresite hranu u košari za prženje.

⚠ **OPREZ:** Ne tresite košaru za prženje snažno kako biste izbjegli prskanje hrane i kako se ne biste opekli.
⚠ **OPREZ:** Oprezno postupajte s vrućim površinama dok upotrebljavate uređaj.

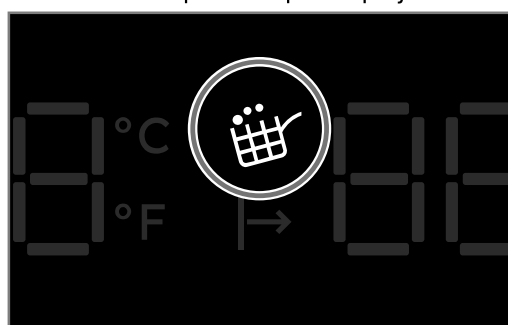

Podsjetnik za protresanje

"Podsjetnik za protresanje" se aktivira tijekom funkcije Air Fry zajedno s unaprijed postavljenim receptima kao što su Povrće, Riba, Pileći bataci i Odrezak.

Kada je vrijeme za protresanje ili okretanje hrane, ikona "Podsjetnik za protresanje" će se uključiti i treptati jednu minutu, dok će se zvučni signal ponoviti tri puta.

"Podsjetnik za protresanje" nije obavezan, stoga će se priprema hrane nastaviti prema uobičajenom postupku čak i ako je ne okrenete ili ne protresete.

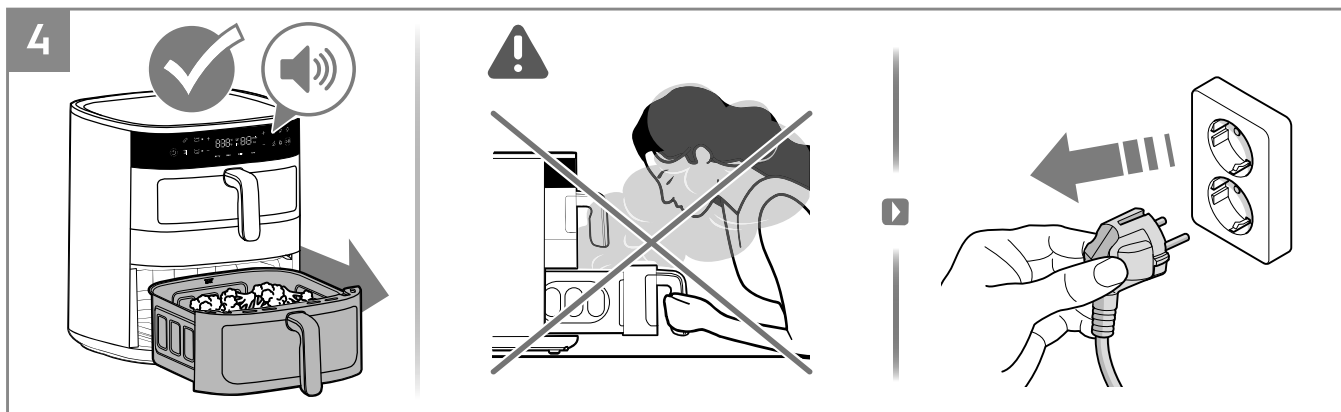

4. Po isteku vremena pripreme hrane, uređaj će se oglasiti zvučnim signalom. Pažljivo izvadite košaru i stavite je na površinu otpornu na toplinu. Iskopčajte uređaj nakon upotrebe.
- ⚠ OPREZ:** Ako košaru otvorite usred ili nakon završetka kuhanja, može izaći vruća para. Odmaknite lice, ruke i šake od pare prilikom otvaranja.

Kako koristiti – gornja + donja košara

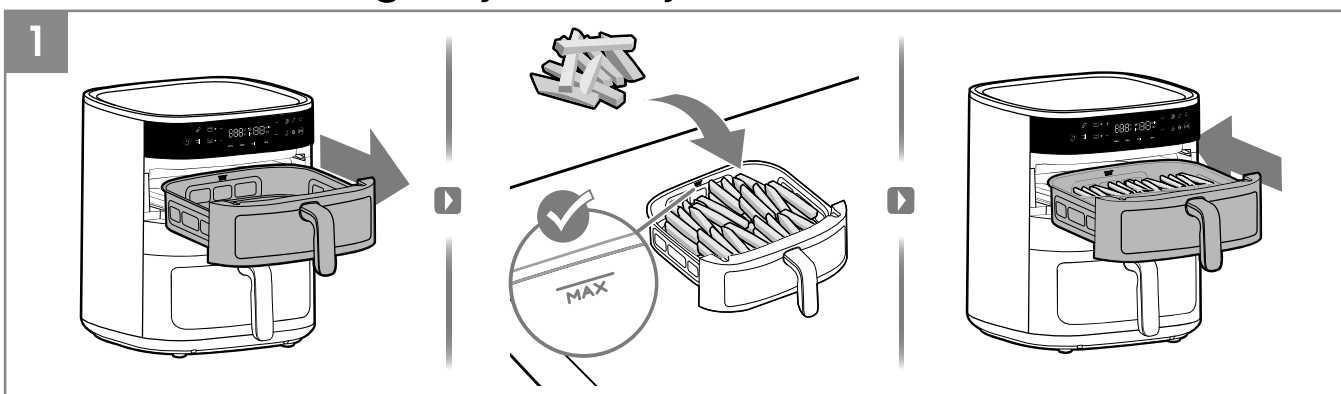

1. Prvo izvucite gornju košaru i stavite hranu u istu, primjerice, krumpiriće.

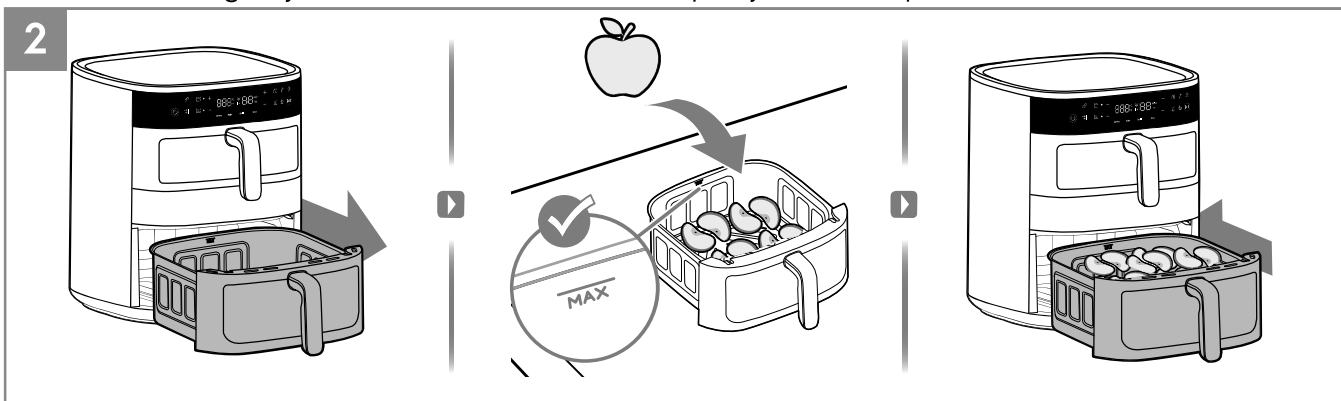

2. Zatim izvucite donju košaru i stavite hranu u istu, primjerice, kriške jabuke.



3. Pritisnite gumb za uključivanje/isključivanje. Prvo odaberite gornju košaru. Zatim odaberite željeni način pripreme hrane, primjerice, funkciju Air Fry. Prilagodite vrijeme i temperaturu na željenu razinu ili odaberite jedan od unaprijed postavljenih recepata, primjerice, Povrće. Naposljetku pritisnite gumb za reprodukciju/pauzu.



4. Zatim odaberite donju košaru. Nakon toga odaberite željeni način pripreme hrane, primjerice, funkciju sušenja. Prilagodite vrijeme i temperaturu na željenu razinu. Naposljetku pritisnite gumb za reprodukciju/pauzu.

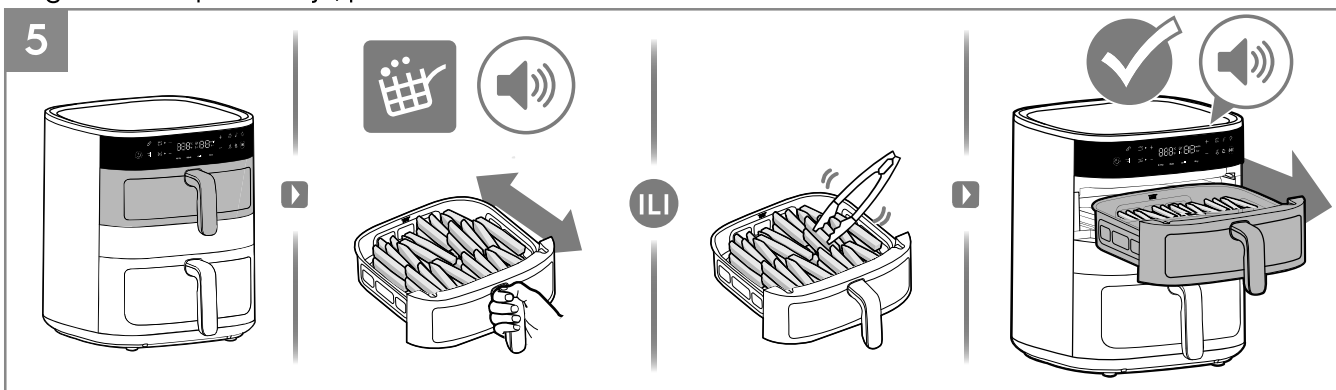

5. Ako se tijekom pripreme hrane uključi ikona "podsjetnika za protresanje" i oglasi se zvučni signal, alatima otpornima na toplinu jednom okrenite hranu ili lagano i pažljivo protresite hranu u košari za prženje. Po isteku vremena pripreme hrane u gornjoj košari, uređaj će se oglašiti zvučnim signalom.

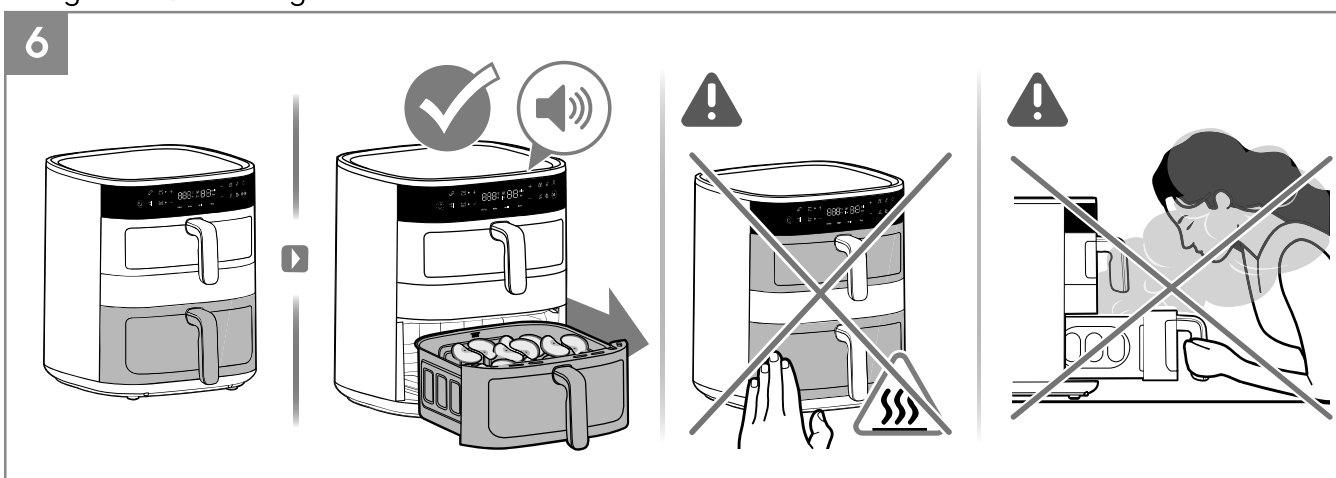

6. Po isteku vremena pripreme hrane u donjoj košari, uređaj će se oglašiti zvučnim signalom.

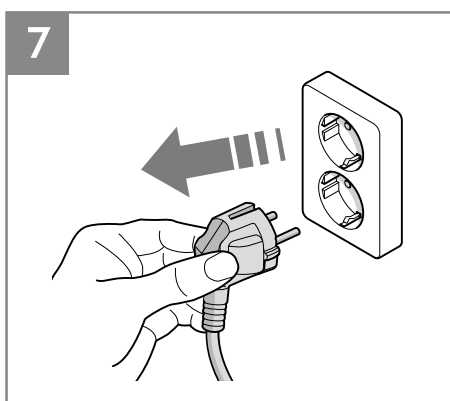

7. Iskopčajte uređaj nakon upotrebe.

Kako koristiti – funkcija povezivanja

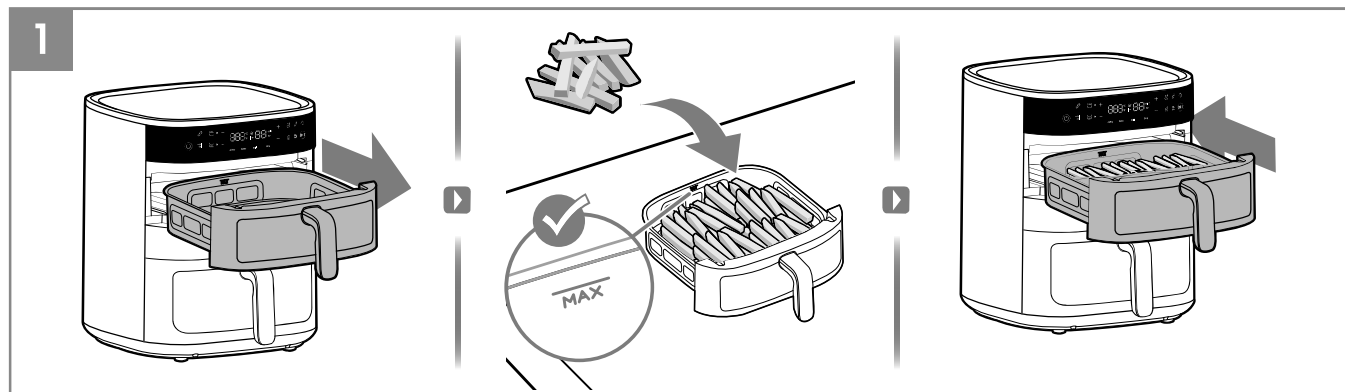

1. Prvo izvucite gornju košaru i stavite hranu u istu, primjerice, krumpiriće.

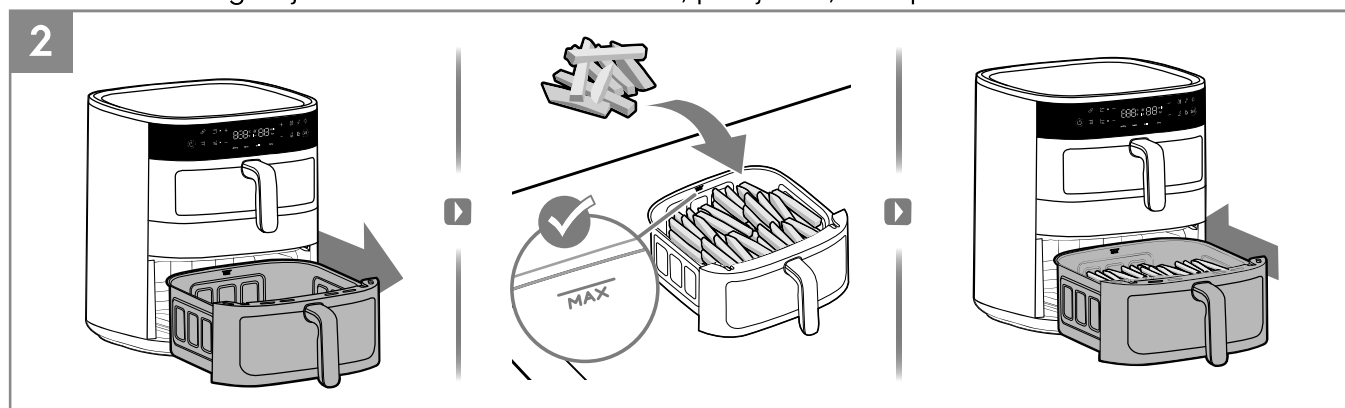

2. Zatim izvucite donju košaru i stavite hranu u istu, primjerice, krumpiriće.



3. Pritisnite gumb za uključivanje/isključivanje. Prvo odaberite funkciju povezivanja. Zatim odaberite željeni način pripreme hrane, primjerice, funkciju Air Fry. Prilagodite vrijeme i temperaturu na željenu razinu ili odaberite jedan od unaprijed postavljenih recepata. Naposljetku pritisnite gumb za reprodukciju/pauzu.

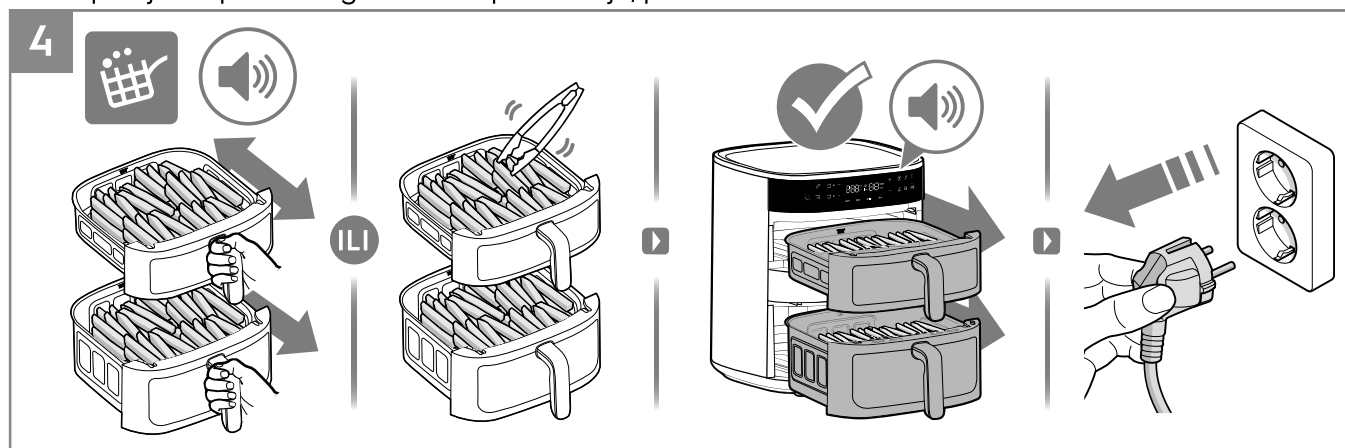

4. Ako se tijekom pripreme hrane uključi ikona “podsetnika za protresanje” i oglasi se zvučni signal, alatima otpornima na toplinu jednom okrenite hranu ili lagano i pažljivo protresite hranu u košari za prženje. Po isteku vremena pripreme hrane, uređaj će se oglasiti zvučnim signalom. Iskopčajte uređaj nakon upotrebe.

Kako koristiti – funkcija sinkronizacije završetka

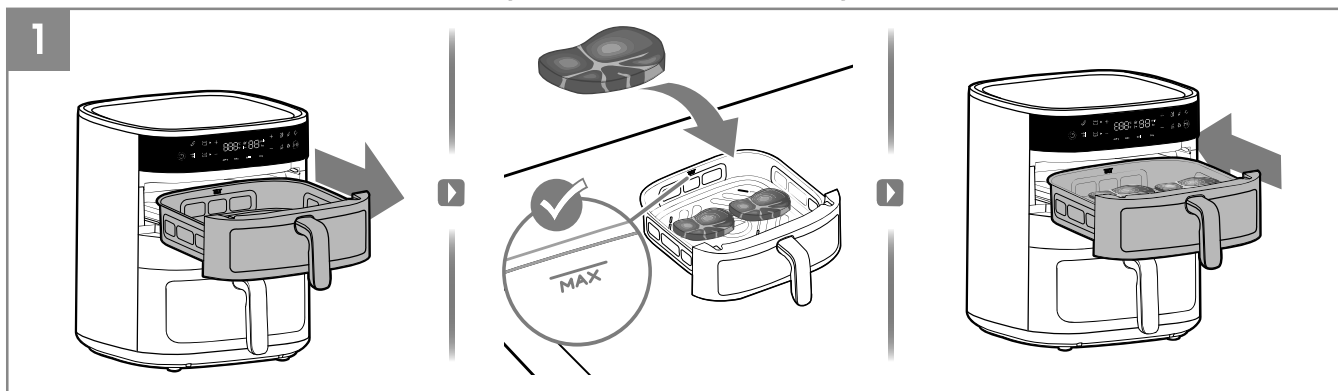

1. Prvo izvucite gornju košaru i stavite hranu u istu, primjerice, odrezak.

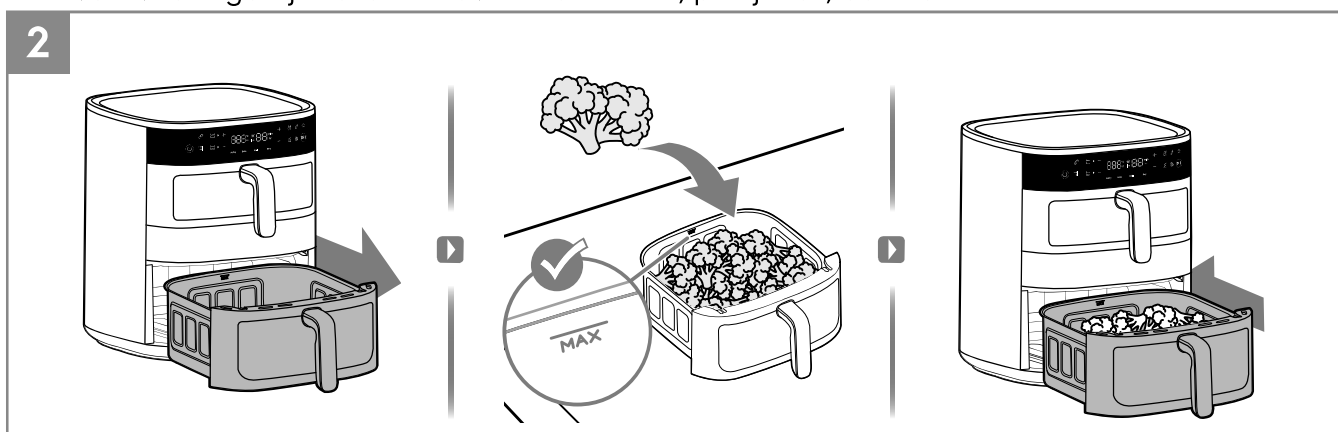

2. Zatim izvucite donju košaru i stavite hranu u istu, primjerice, brokulu.



3. Pritisnite gumb za uključivanje/isključivanje. Odaberite funkciju sinkronizacije završetka. Prvo odaberite gornju košaru, zatim odaberite željeni način pripreme hrane, primjerice, funkciju Air Fry. Prilagodite vrijeme i temperaturu na željenu razinu ili odaberite jedan od unaprijed postavljenih recepata, primjerice, Odrezak.



4. Zatim odaberite donju košaru i odaberite željeni način pripreme hrane, primjerice, funkciju Air Fry. Prilagodite vrijeme i temperaturu na željenu razinu ili odaberite jedan od unaprijed postavljenih recepata. Naposljetku pritisnite gumb za reprodukciju/pauzu.

- EN
- BG
- CZ
- DE
- DK
- EE
- FI
- FR
- GR
- HR**
- HU
- IT
- LT
- LV
- NO
- NL
- PL
- PT
- RO
- RU
- SE
- SI
- SK
- SR
- TR
- UA
- ES
- GE
- AL

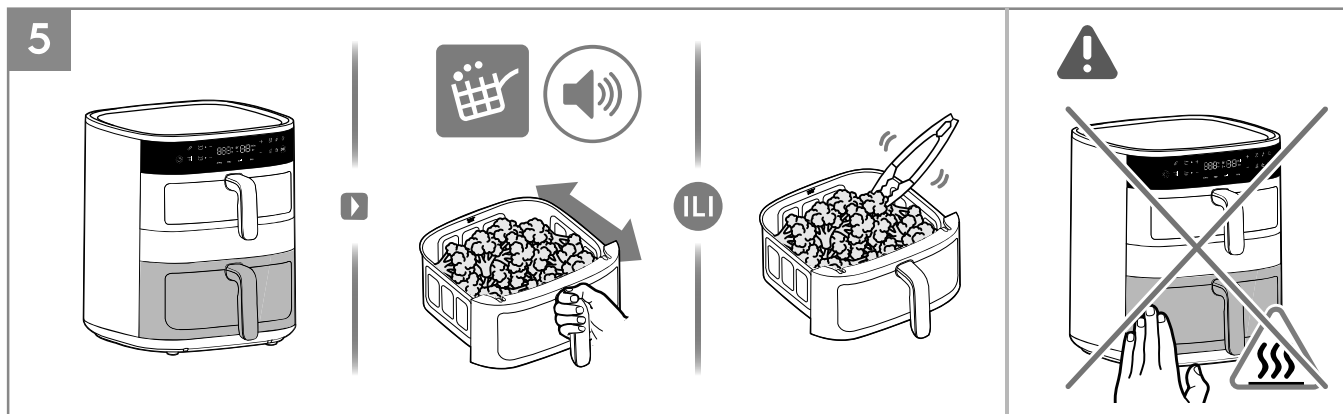

5. Prvo, donja košara s većim postavljenim vremenom imat će prioritet u pripremi hrane. Ako se tijekom pripreme hrane uključi ikona “podsetnika za protresanje” i oglasi se zvučni signal, alatima otpornima na toplinu jednom okrenite hranu ili lagano i pažljivo protresite hranu u košari za prženje.

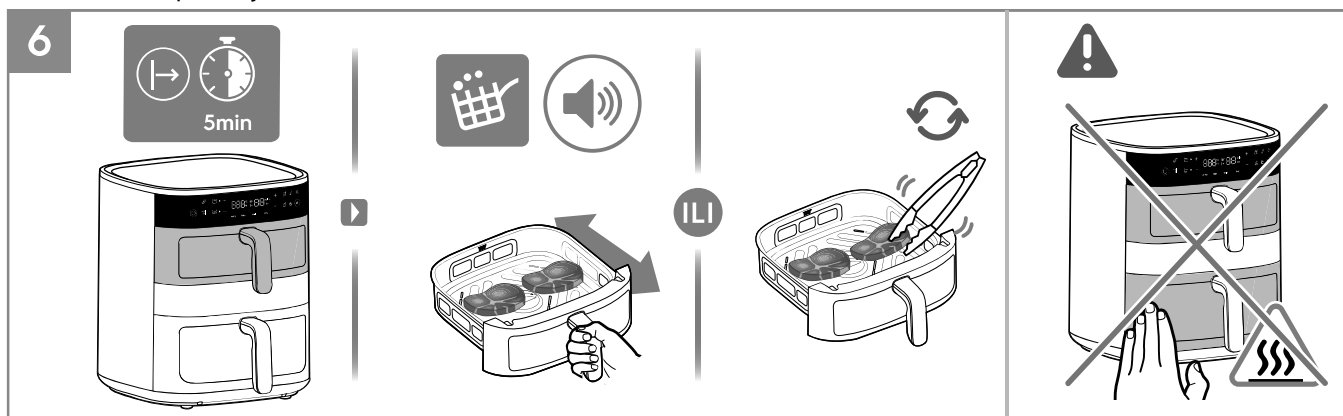

6. Drugo, gornja košara s kraćim postavljenim vremenom započet će s pripremom hrane. Ako se tijekom pripreme hrane uključi ikona “podsetnika za protresanje” i oglasi se zvučni signal, alatima otpornima na toplinu jednom okrenite hranu ili lagano i pažljivo protresite hranu u košari za prženje.

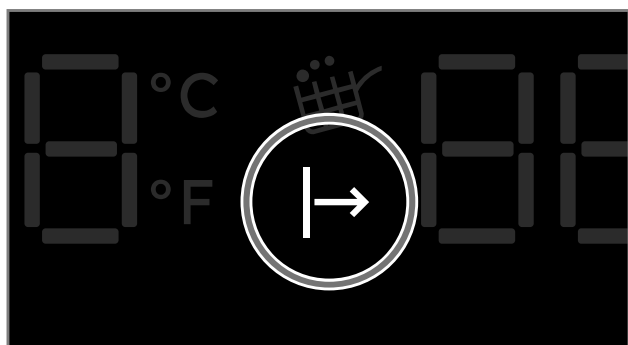

Indikator čekanja pripreme hrane

Ako je aktivirana “Funkcija sinkronizacije završetka”, košara s kraćim vremenom pripreme hrane pričekat će da košara s većim vremenom pripreme hrane počne pripremati hranu neko vrijeme, tako da obje košare mogu završiti pripremu istovremeno. Tijekom tog razdoblja, “indikator čekanja pripreme hrane” će svijetliti dok priprema hrane ne započne.



7. Po isteku vremena pripreme hrane, uređaj će se oglasiti zvučnim signalom. Iskopčajte uređaj nakon upotrebe.

Čišćenje

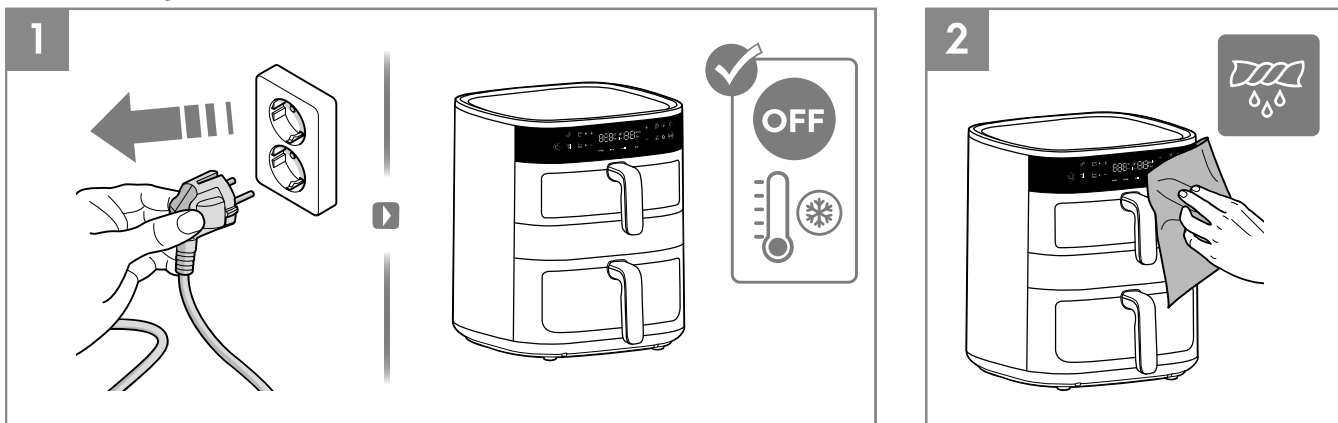

1. Svakako isključite uređaj iz struje i pričekajte da se ohladi prije čišćenja.
2. Obrišite uređaj izvana mekom krpom.

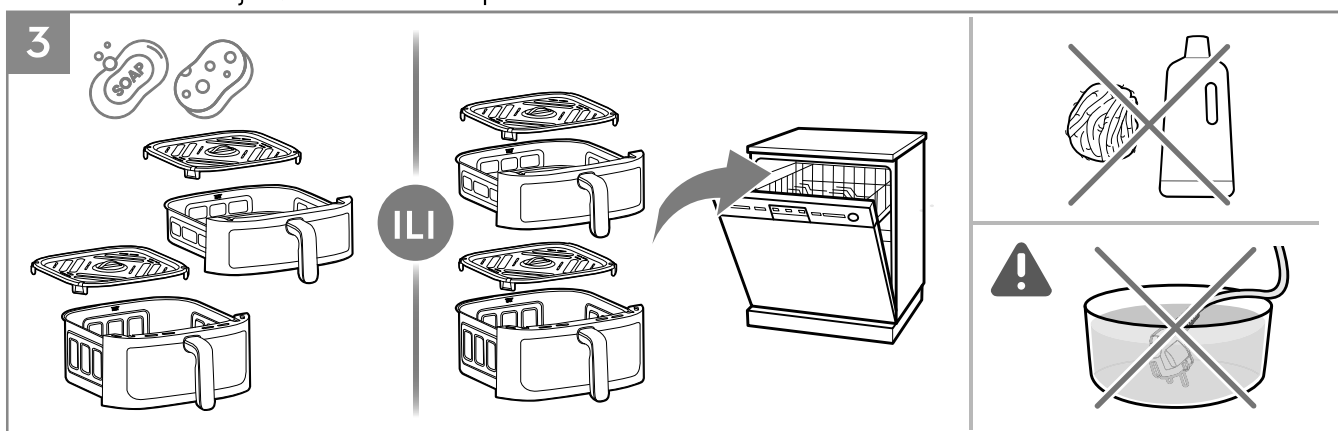

3. Očistite posudu i rešetku toplom vodom i sapunom za posuđe ili ih stavite u perilicu posuđa.

▲NAPOMENA: Nemojte koristiti abrazivna sredstva za čišćenje ili metalne alate kako biste zaštitili neprianjajući površinski sloj.



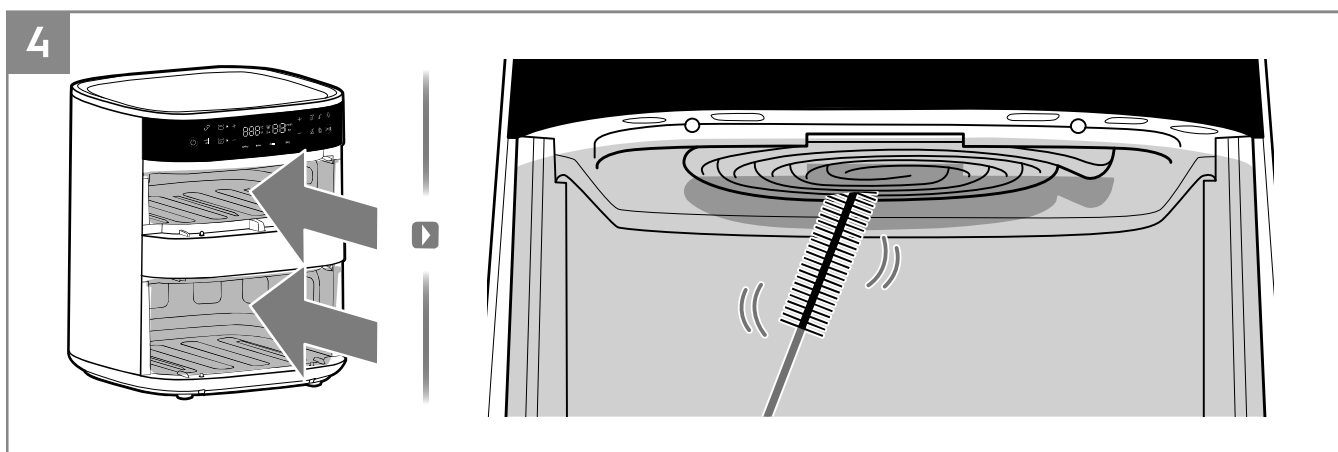









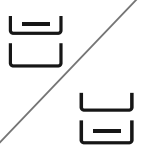

















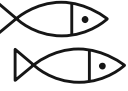

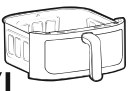





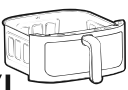



OPREZ: Nikako ne uranjajte proizvod, njegov kabel ili utikač u vodu ili bilo koju drugu tekućinu.













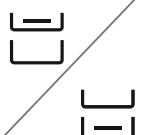







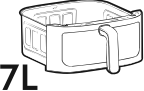
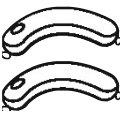

4. Očistite grijaći element četkom za čišćenje.

NAPOMENA: Prije čišćenja grijaćeg elementa uvjerite se da se uređaj potpuno ohladio.

Vodič za pripremu hrane

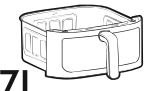
							
	7mm/10mm 	 4L	400g	180°C	18min		
		 7L	400g	180°C	18min		
		 4L	400g	170°C	8min		
		 7L	400g	170°C	10min		
		 4L	400g/2komada	140°C	15min		
		 7L	400g/2komada	140°C	15min		
		 4L	1000g/8komada	180°C	28min		
		 7L	1000g/8komada	180°C	28min		
		 4L	400g/2komada	200°C	10min		
		 7L	400g/2komada	200°C	10min		
		 4L	220g/6inča	160°C	12min		
		 7L	220g/6inča	160°C	14min		

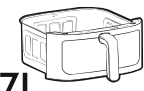
							
AirFry		 7L	1200g	180°C	55min		
AirFry		 7L	400g/9komada	160°C	20min		
Grill		 4L	180g/4komada	180°C	8min		
		 7L	180g/4komada	180°C	9min		
Dry		 4L	180g	80°C	3h		
		 7L	180g	80°C	3h		
Dry		 4L	200g	80°C	3h		
		 7L	200g	80°C	3h		

EN
BG
CZ
DE
DK
EE
FI
FR
GR
HR
HU
IT
LT
LV
NO
NL
PL
PT
RO
RU
SE
SI
SK
SR
TR
UA
ES
GE
AL

Što ako...

Problem	Provjerite...
Ne možete aktivirati ili upravljati uređajem.	<ul style="list-style-type: none"> • Uređaj je ispravno spojen na električnu mrežu. • Košare su u ispravnom položaju. Uvjerite se da su do kraja gurnute u uređaj kako biste omogućili napajanje električnom energijom. • Vrijeme pripreme hrane je postavljeno.
Ne možete gurnuti košaru u uređaj.	<ul style="list-style-type: none"> • Košara je napunjena preko kapaciteta. • Košara je ispravno postavljena. Treba sjesti na mjesto kada je postavite u uređaj. • Ispod košare se nalazi predmet koji sprječava njezino pravilno zatvaranje.
Iz uređaja izlazi bijeli dim.	<ul style="list-style-type: none"> • Hrana koju pripremate je premasna. • Košara, rešetka i grijaći element su čisti.
Na zaslonu se prikazuje E1	• Otvoreni krug gornje košare.
Na zaslonu se prikazuje E2	• Otvoreni krug gornje košare.
Na zaslonu se prikazuje E3	• Otvoreni krug donje košare.
Na zaslonu se prikazuje E4	• Kratki spoj donje košare.
Na zaslonu se prikazuje E5	• Pogreška komunikacije upravljačke tiskane pločice.
Na zaslonu se prikazuje E6	• Pogreška komunikacije tiskane pločice napajanja.

* Ako se na zaslonu prikažu kodovi pogrešaka, uređaj je potrebno popraviti u servisnom centru.

Tehnički podaci

Proizvod	Friteza na vrući zrak
Model	EAFD11B
Napon (V ~)	220 V ~ 240 V
Snaga (W)	2700 W
Frekvencija (Hz)	50 ~ 60 Hz
Kapacitet	4 L + 7 L